

Annex 16.4: Examples of different types of Remedial Actions

In order to manage power systems under full security of supply, equipment and persons, physical flows on the grid need to be controlled within each part of the grid.

This principle must be applied to N-situation (without any outage), and also to hypothetical so-called N-K situations (by anticipating outages of some part (line(s)/transformer/busbar/generation unit) of the network). Indeed, TSOs have the obligation to be robust to the losses of any individual part of their network.

Distribution of flows within a network is based on 2 main factors:

1. Distribution of load and generation in the interconnected network (which create the electrical inputs and outputs)
2. Characteristics of the network (for example, impedance of lines and topology)

Aim of a Remedial Action is to adjust the flows on the network in an acceptable way in terms of Security of Supply (generally means n-1 security), by modifying one of these factors. 'Acceptable', but of course never perfect, because each improvement of the situation in one part of the network will affect another part of it (by principle of a meshed network).

Knowledge of operators (from planning to real-time) is there to manage all the Remedial Actions, in order to find the best compromise between all of them, in respect of the Security of supply rules, to the lowest cost necessary, and allowing the maximum of exchanges between and inside countries.

For CWE Flow-Based Capacity Calculation, the following types of Remedial Action (RA) can be taken into account explicitly from a technical perspective:

- changing the tap position of a phase shifter transformer (PST) (above mentioned factor 2)
- topological measure : opening or closing of a line, cable, transformer, bus bar coupler, or switching of a network element from one bus bar to another (factor 2)
- redispatching: changing the output of some generators or a load. (factor 1)
As it is a costly measure, redispatching is often a curative (post-fault) remedial action.
- TSOs can perform adjustments on the load (« load shedding »).

Each TSO can choose its own set of RAs depending on the local risk policy and availability, e.g. for some TSOs costly RAs are not allowed during capacity calculation stage.

1. Phase shifter transformer (PST)

By principle, changing some taps on a PST is done to modify the flow on one line (it could be increase or decrease), to the cost of a transfer of power on other lines.

In this example, if you look at the situation below in Belgium, flows are going mainly from Germany (through Netherlands), and less from France, and are quite well distributed between lines from East and from West.

At the north border of ELIA (Belgian grid), there are 3 PSTs, which are able to manage the flows between East and West, and also between North and South, when all PSTs are used.

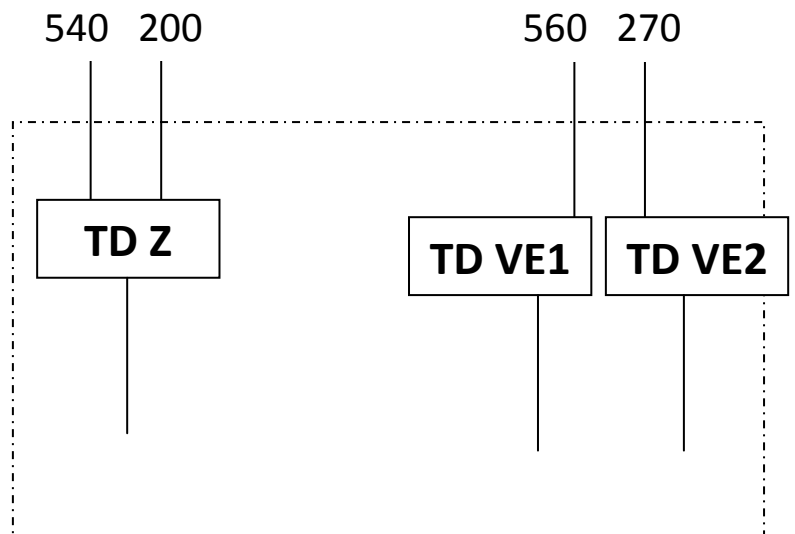
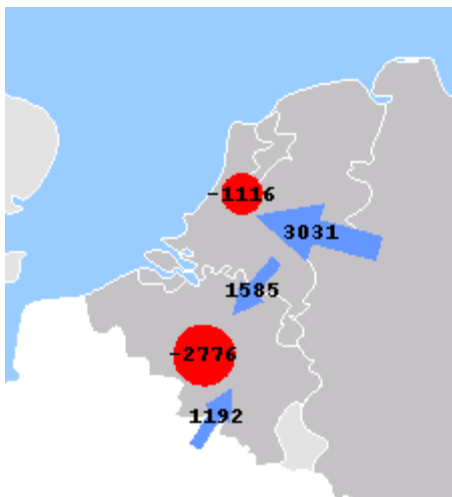

By adjusting the taps on only one PST, we are able to decrease the flows on East Part, in cost of increased flows on West Part.

It's a solution which can be used only if constraints are less important on the West Part.

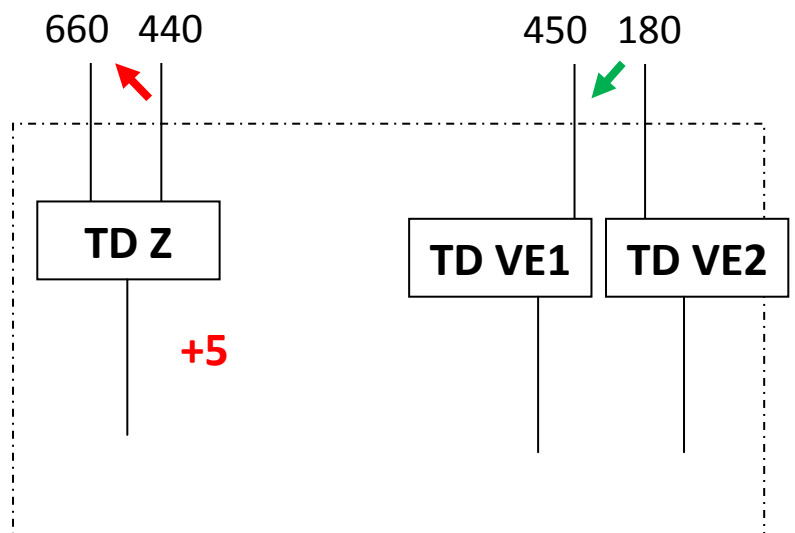
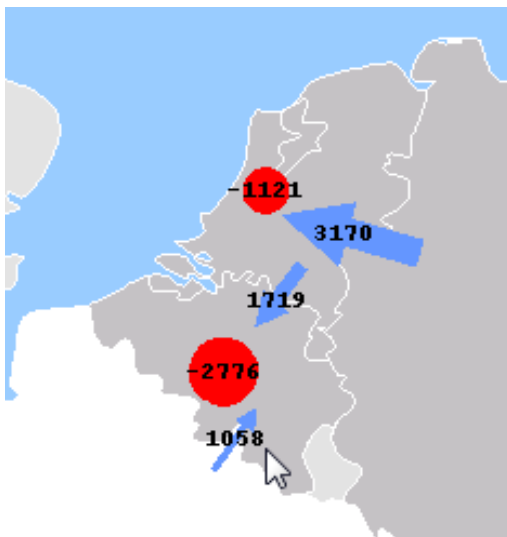

By adjusting the taps on all PSTs in the same direction, it's possible to manage the flows on the full border. Nevertheless, this action impacts the flows in the neighbouring network, of which a proper assessment is always required.

In this case, we can see a big impact on the NL > BE flows (-350 MW), in cost of course on flows on the FR > BE borders, which is increased by the same value.

It's a solution which can be used only if constraints are less important on the South Part.

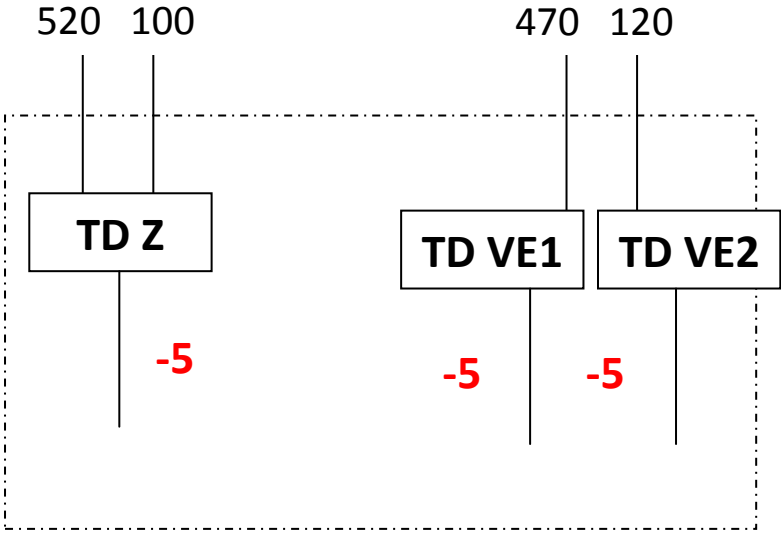
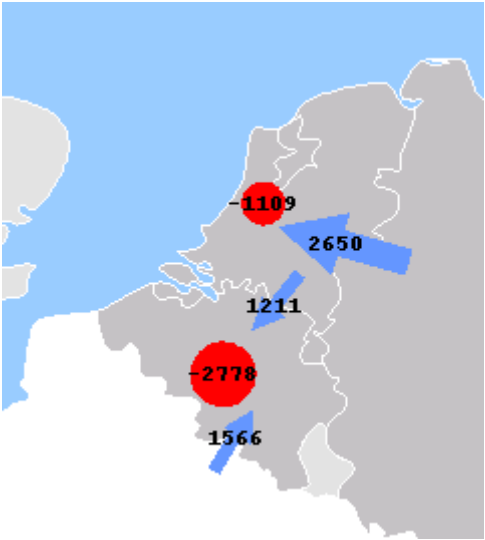

When PSTs are used on regional level, for example to control the flows on some specific border, it often needs coordination between the TSOs of the area to manage all the impacts (because degradation of the situation is not always in the area of the controller who uses PSTs to improve his network).

Simple situation presented here as an example is also more difficult to manage in reality, due to the fact that during the FB process, TSOs have to consider all possible N-1 situations, without knowing for sure in advance in which direction the market will go. For all these N-1, one has to find an acceptable solution for all PSTs which could be valid for most of the market directions, especially the likely one.

That's the aim of the PST coordination task in the FB process.

2. Topological Measure

Idea behind the topological measure is to adapt the network, by modifying his impedance and by putting away the source of flows (generation/load) from the monitored line.

It's mainly a non-natural decision for a TSO, because the network is much more secure and robust when substations are full meshed. Losses are also smaller (dividing the network have a (small) cost).

Good examples can be found in the substation of Vigy, in France:

2 interconnectors (FR > DE, XEN_VI11/12), 2 Transformers (400kV > 225kV), 4 nuclear units and many lines.

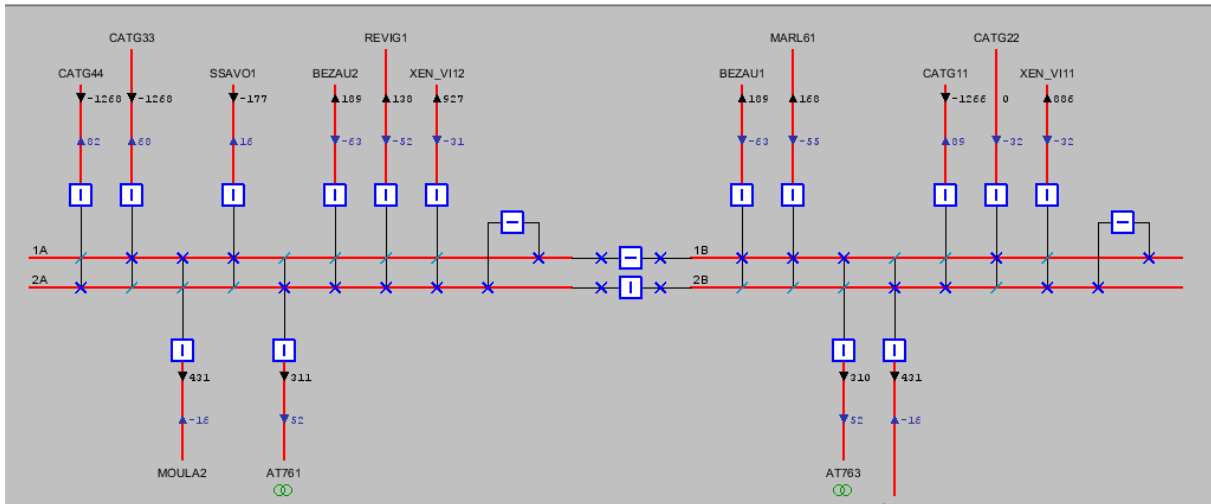

We are going to look at the remedial actions to use in case of outage on one of the 2 interconnectors towards Ensdorf in Germany (outage of XEN_112, following diagram).

With one node at Vigy, we have about 1700 MW on the remaining line (XEN_VI11), which is close to the maximum limit (1880 MW), so highly constraining for new exchange between France and CWE.

Impact of FR > DE exchanges on this remaining line is of 25% in this situation.

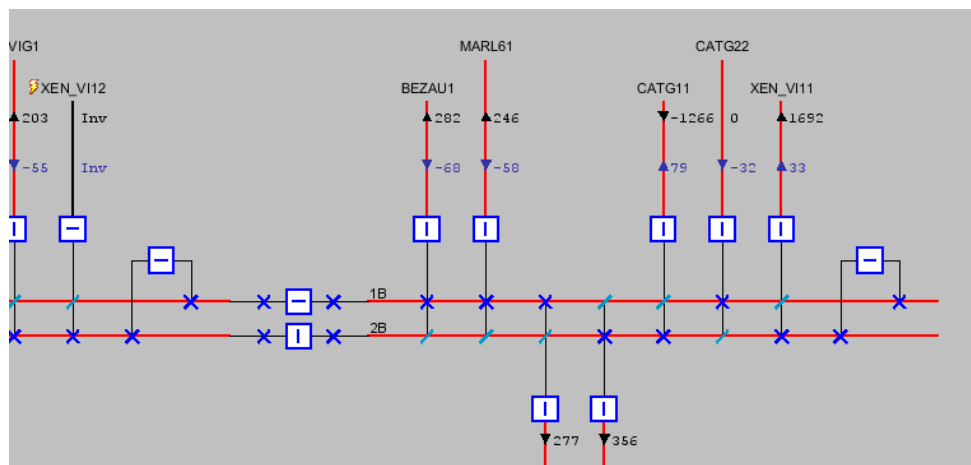

First simple solution is to cut the substation in 2 parts, and put away from the remaining line 2 nuclear units and half lines of the substation. In general, it let to each node enough lines to keep an acceptable level of security. It can even be taken as preventive action in some case.

Flow has been decreased by 170 MW and sensitivity to FR > DE is now 21%

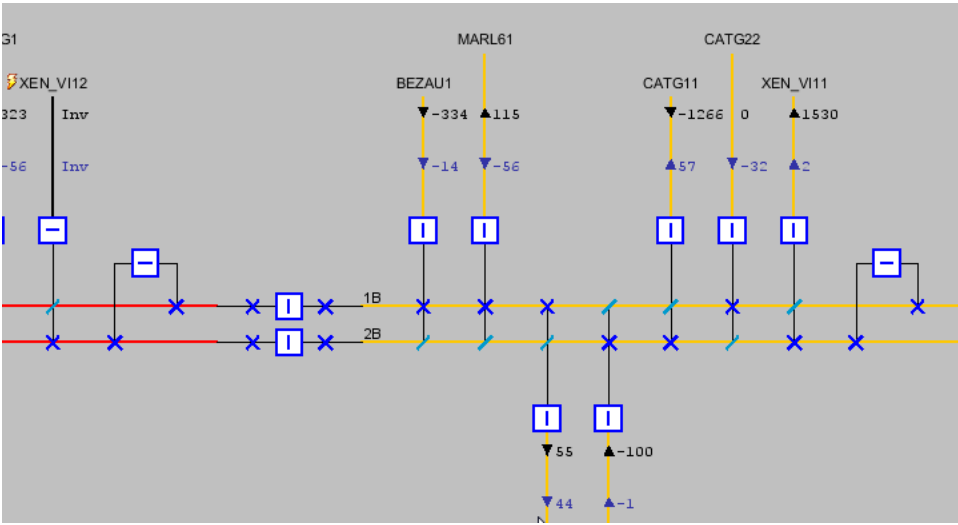

Second solution is to decrease the size of the new node, by cutting the substation in 1/4 - 3/4

The level of security is of course smaller in this case (we only have 3 lines of the remaining node, with one generation unit).

It's not always possible to use this remedial action, due to other constraints (stability on one of the nuclear units, possibility to put some lines with the others), and also due to the impact on others lines (well known mutual impact on other lines, every MW decreased on one side is increased elsewhere).

But flows have been again decreased by 100 MW, and sensitivity to FR > DE is now 15%.

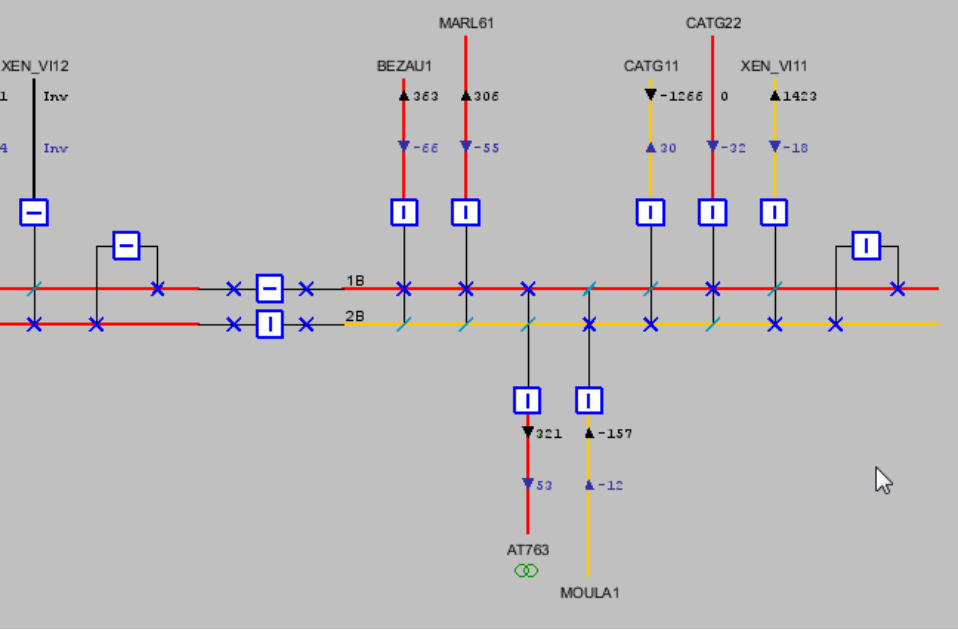

It's of course not always possible to use 2 or 3 nodes everywhere in the network, main reasons being that the substation have to be fully adapted (enough lines, enough breakers, enough busbars), and also remedial actions have to be compatible in the needed timing (no manual action for example).

3. Redispatching

Idea behind the redispatching is not any more to adapt the network to manage the flows, but now to adapt the source of flows (generation/load). It is of course not really possible to manage the load in large area (but it could be done on small area, for example by switching some transformer to transfer the load on another transformer).

Adapting the generation is more feasible, but only when units can be modified (which is not always the case), when units used to compensate redispatching are far enough from the first one, and also when the relieving effect on the constraint is strong enough to justify the additional cost of redispatching borne by TSOs. This kind of remedial action has almost no impact on exchange sensitivity (only a small one when the unit was a part of the GSK), so it is often used in combination of topological remedial action.

For these reasons:

- It is very difficult to consider this kind of remedial action before Real-Time, because TSO operators do not have, in D-2, a reliable view on the units that could be available for potential redispatching actions.
- It is much more usable on areas which are large enough to have available generation far away from the constraint. Otherwise, the compensation of the redispatched unit, necessary to maintain the global balance on the grid, can affect the effectiveness of the redispatching action.
- There are often flexible hydraulic units used in this way (higher level of availability, compatible reaction time, less operational constraints)
- It is only possible when units are available close to the constraint (otherwise the positive impact is too low).

To conclude, redispatching Remedial Actions are subject to many technical constraints that limit their usage within the CWE area, at capacity calculation stage and in real time. What's more, one should keep in mind that the usage of costly RA (as for any type of RA in fact) is strictly ruled at local level by specific risk policies, therefore there could be differences at implementation level. Finally, it is to be reminded that currently there exists no harmonized CWE- framework for coordinated cross-border redispatching considerations applied at internal level at capacity calculation stage.